

Sapa Building System

Solar Shading

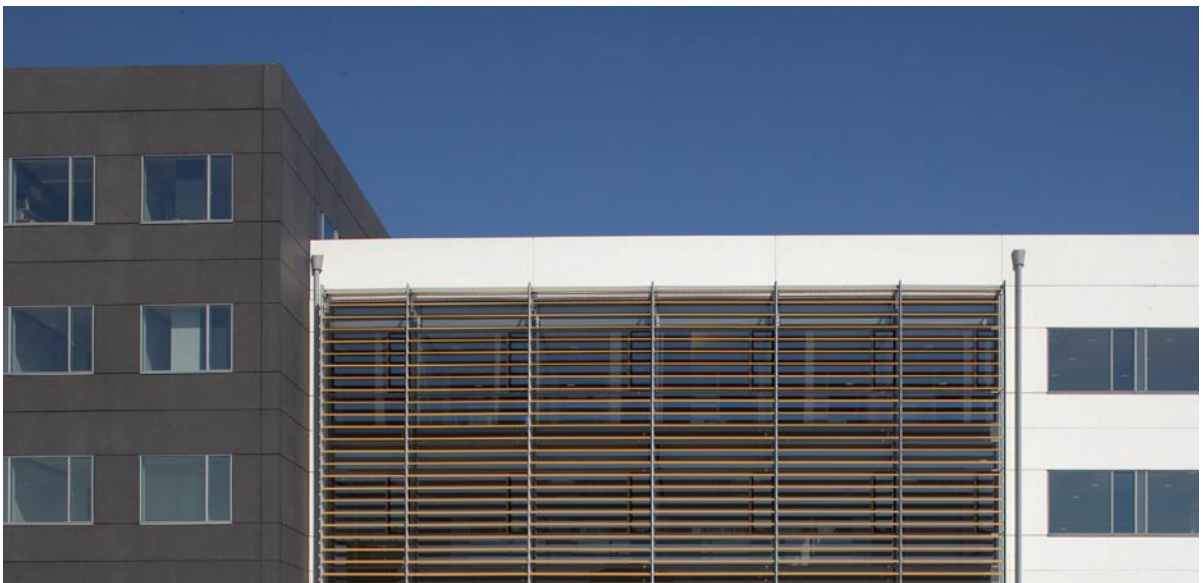



Sapa Building System AB

We develop, market and stock system products made of aluminium profiles for:

- **Sapa Building Systems:** doors, windows, facades, glazed roofs, solar protection, balustrades and boarding.
- **Sapa Transport Systems:** vehicle platforms and sides, headboards, doors and underrun protection.
- **Sapa Floor Systems:** mezzanine floors, stairs, industrial railings, driving decks for bridges and flagpoles.

Our products are developed so as to withstand the hard Scandinavian climate and to fulfil the strict construction standards and market requirements. A close co-operation with architects and designers at the decision-making stage supports our development efforts and helps us meet the future requirements. The quality of Sapa Building System AB is ensured by ISO 9001.

We have full control of the entire production chain from manufacturing of dies, extrusion of profiles, surface treatment and thermal insulation to the warehousing of all profiles and accessories. The systems are advertised to architects, consultants and final customers.

The production of the final products is done through a network of independent specialist companies. Apart from the production, their commitment also includes providing ideas and advice concerning our manufacture, delivery, installation and after-sales service.

Our head office is located in Vetlanda, Sweden. We have sales offices in Norway, Denmark, Finland, United Kingdom and Lithuania.



Sapa Building System SFB 4550

Solar Shading

Today's architecture is dominated by glass and transparency. Glazed walls create a visual openness between the outside and the inside. We need the daylight, the sunshine and the view. However, the interior climate and working environment are strongly influenced by the sunshine. The installation of external solar protection is a good way to keep away light and heat.

Sapa Solar Shading is a simple and elegant complement to our facade system SFB 4150. The system is based on three types of louvers: Bow, Wing and Box, which give the architect a great deal of freedom in the choice of form and function.

There are many possibilities to design the solar protection. We offer solutions for visually unbroken solar protection and for distinct division into sections. The user can choose the architectural rhythm to be created. With the help of our decorative profiles, the appearance of the bearing profiles can be emphasised in order to harmonize with the architecture of the building.

Buildings in Scandinavia are exposed to harsh Nordic climates. Sapa Solar Shading, made of extruded aluminium profiles ensures the required strength and stability while reducing the maintenance needs.





Bow

The springy bow form lends lightness to the facade. The form reflects the sunshine and can provide indirect, soft lighting for the rooms. The surface treatment can additionally emphasise the form and expression of the profiles. The solar protection can be arranged vertically or horizontally. It can be installed as a self-bearing structure or as a secondary structure on another bearing framework.

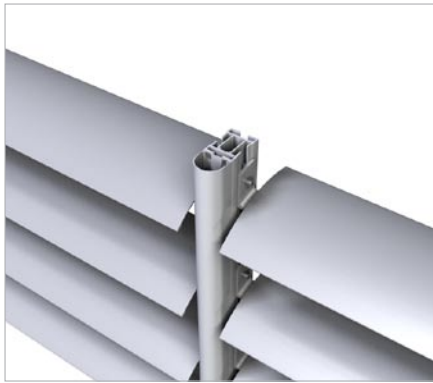

Alternative 1, vertical



Alternative 3, horizontal

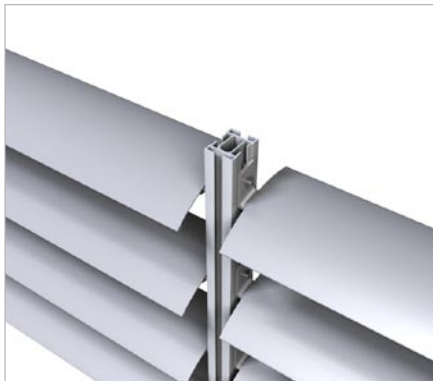

Alternative 2, vertical



Alternative 4, vertical

Alternatives 1, 2 and 3: The unattached louvers are installed directly on the bearing profile, which can be arranged vertically or horizontally. The vertical line can be additionally emphasised by installing decorative profiles from the Expressive family of the SFB 4150 system.

Alternative 4: The louvers are screwed to the end/side profiles, which makes it possible to pre-fabricate sections. The sections are installed vertically on aluminium bearing profiles. This alternative gives a discreet appearance and a clear visual profile.

Fittings: Complete set of fittings for fixed installation of louvers at an angle of 0°, 15°, 30° or 45°.

Louvers: 190 or 300 mm wide.

Surface finish: Anodising or powder coating.



Bow

The College in Halmstad, Sweden – Campus 2 – was designed by the company Fredblad Arkitekter of Halmstad and completed by the autumn term of 2005. The Bow 300 louvers form the solar protection of the south and west SFB 4150 glazed facade. The facade is provided with the Add decorative profiles with integrated grooves in order to ensure wind load stiffness of the solar protection. The vertical bearing profiles transfer the dead weight load of the solar protection to the custom designed steel frame, which in turn is fixed to the top and bottom edges of the concrete wall. Design-wise the division into sections is emphasised with the vertical Expressive decorative profile 68819. The louvers are powder coated in a shade of yellow, NCS-S 3040-Y20R, while the vertical fittings and the decorative profiles are supplied in a shade of grey, NCS-S 3502-G.

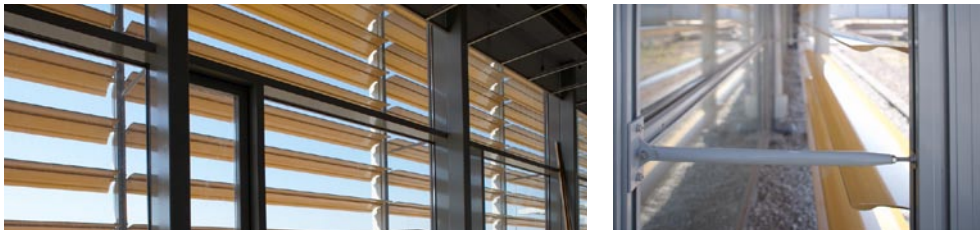





Wing

As the profile meets the light and the wind in a soft manner, the form takes your thoughts to aerodynamics. The Wing, installed in an unbroken line, gives a minimum visual division into sections. The surface finish can additionally emphasise the form and expression of the profile. The solar protection can be arranged vertically or horizontally. It can be installed as a self-bearing structure or as a secondary structure on another bearing framework.

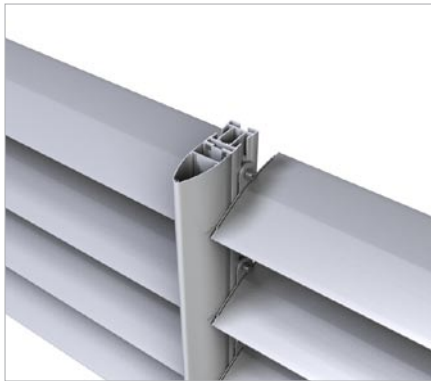

Alternative 1, vertical

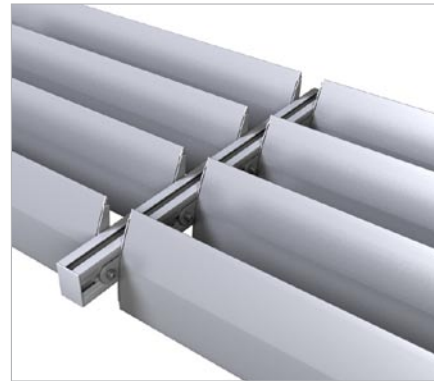

Alternative 3, horizontal



Alternative 2, vertical



Alternative 4, vertical

Alternatives 1 and 3: The unattached louvers are installed directly on the bearing profile, which can be arranged vertically or horizontally. The vertical line can be additionally emphasised by installing decorative profiles from the Expressive family of the SFB 4150 system.

Alternative 2: The unattached louvers are installed directly on the bearing profile in a so-called unbroken line, which gives the impression of a clear direction.

Alternative 4: The louvers are screwed to the end/side profiles, which makes it possible to pre-fabricate sections. The sections are installed vertically on aluminium bearing profiles. This alternative gives an aerodynamic appearance and a clear visual profile.

Fittings: Complete set of fittings for fixed installation of louvers at an angle of 0°, 15°, 30° or 45°.

Louvers: 190 or 300 mm wide.

Surface finish: Anodising or powder coating.



Reference project SFB 4450

Wing

Sapa's Restaurant in Vetlanda, Sweden, was designed by the company White Arkitekter of Stockholm and opened in the autumn of 2004. The characteristic curved shape is emphasised with the elegant solar protection which hangs down from the roof projection. The vertical bearing frames are supported directly on the Add decorative profiles of the facade. The solar protection comes in pre-fabricated elements, which are installed between the vertical bearing profiles. The Wing louvers are custom designed and installed horizontally (0°) which ensures a good see-through view. The facade system SFB 4150, the Add profiles and the solar protection are natural anodised.



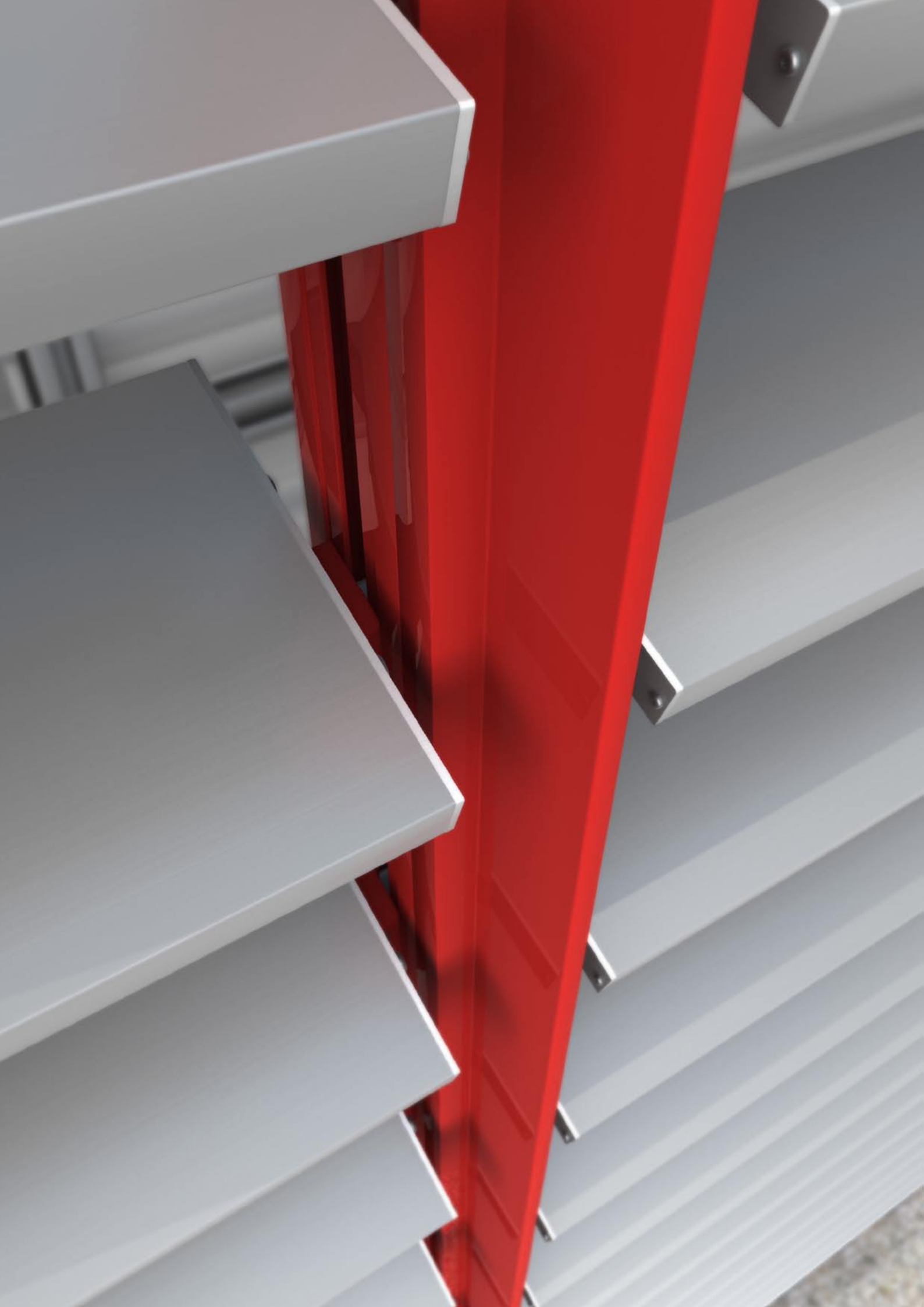

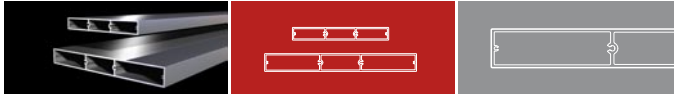

Box

The uncompromising form lends the facade a strong expression. Modernism in aluminium. The surface finish can additionally emphasise the form and expression of the profile. The solar protection can be arranged vertically or horizontally. It can be installed as a self-bearing structure or as a secondary structure on another bearing framework.

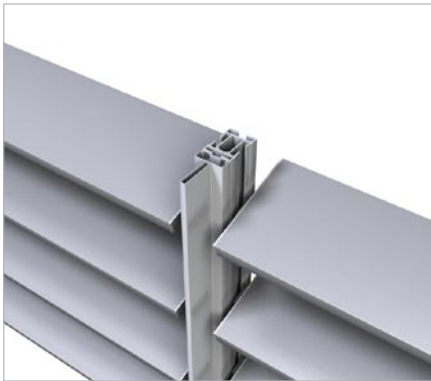

Alternative 1, vertical

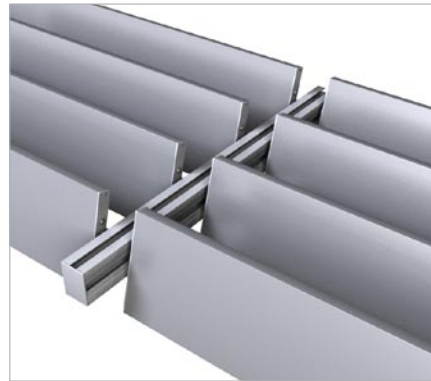

Alternative 3, horizontal

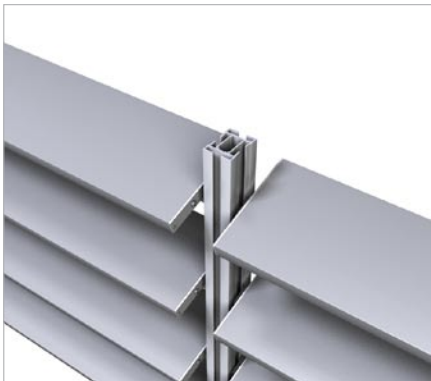

Alternative 2, vertical



Alternative 4, vertical

Alternatives 1, 2 and 3: The unattached louvers are installed directly on the bearing profile, which can be arranged vertically or horizontally. The vertical line can be additionally emphasised by installing decorative profiles from the Expressive family of the SFB 4150 system.

Alternative 4: The louvers are screwed to the end/side profiles, which makes it possible to pre-fabricate sections. The sections are installed vertically on aluminium bearing profiles. This alternative gives a robust appearance and a clear visual profile.

Fittings: Complete set of fittings for fixed installation of louvers at an angle of 0°, 15°, 30° or 45°.

Louvers: 190 or 300 mm wide.

Surface finish: Anodising or powder coating.



Reference project SFB 4550

Box

The new District Court House, designed by the company Arkitektkontoret Ecoscape AB, was built in 2005 on the Polisen block in Helsingborg, Sweden. The south and west facade have been supplied with solar protection. Architecturally, the solar protection has been provided with clear division into sections installed directly on the facade. Add decorative profiles of the facade. The facade system profiles are powder coated in RAL 7024 and the solar protection is natural anodised. The horizontal louvers, installed with a slope of only 3 degrees, preserve the exciting and lively view over the harbour.





SFB 4550 in combination with

the Add design family



SFB 4550 Solar Shading is suitable in places where external solar protection is needed. The installation of the solar protection is adapted to the facade type.

Our facade system SFB 4150 is suited for the installation of Solar Shading through the use of the Add decorative profiles. With Add we have created a console system with a characteristic groove suitable for the addition of special facade functions. The solar protection fittings can be elegant and simple. Even other important functions, such as lighting, signs, rainwater downpipes or lightning conductors, can be installed in the Add profiles.

Simple, with possibilities for future functions.

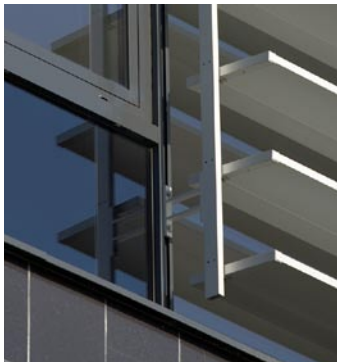

Installation

Architecture and design. Sapa Solar Shading with its three louver types provide a great freedom of choice and a possibility to add and emphasise the architectural values. If required, it can be custom designed. Detail solutions and refined finishing elements are important. It is the entirety that determines which solution is the best one. Every building is unique through its location, use and architecture. We use the three basic designs as the point of departure for our fixed solar protection solutions.

Material. Aluminium is a material that creates good prerequisites for a durable and more resistant solar protection.

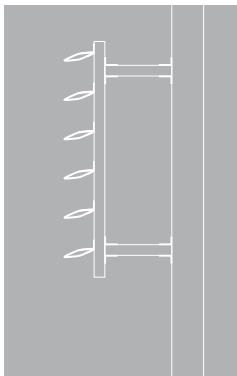

Vertical installation
Self-bearing console
Unbroken louver lines

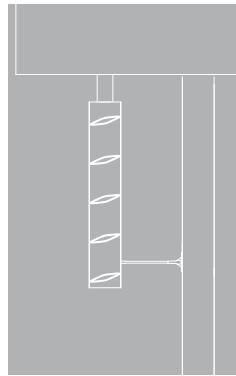

Vertical installation
Hanging console
Broken louver lines

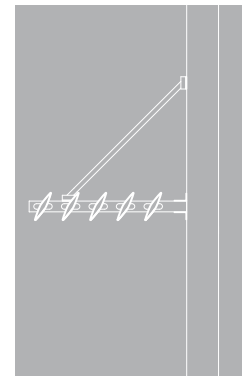

Horizontal installation
Console with tie-rod
Broken louver lines

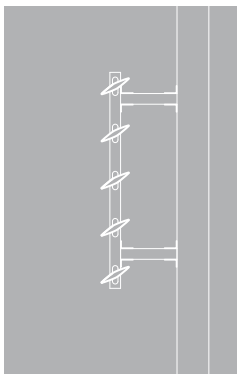

Vertical installation
Self-bearing console
Broken louver lines

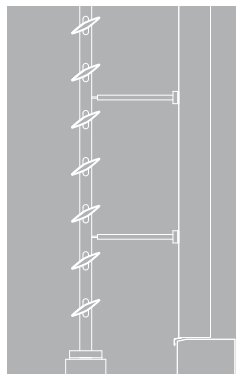

Vertical installation
Ground foundation
Broken louver lines

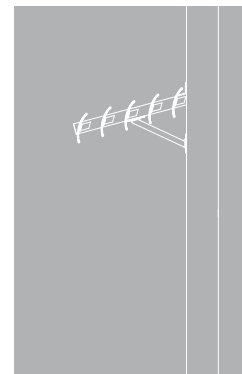

Horizontal installation
Console with support rod
Broken louver lines

Design issues

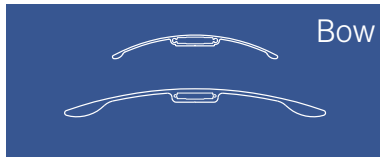

Bow

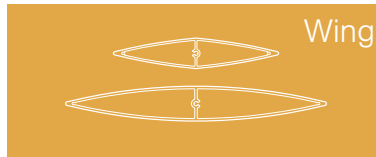

Wing

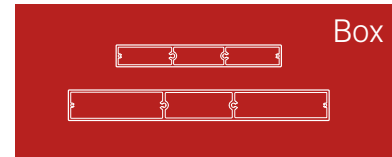

Box

Some important issues to take into account when planning solar protection

Statical issues

Dead weight
Linear expansion
Wind load
Snow and ice load
Working load (for example window cleaners)

Solar radiation

Ecliptic during the year
Geographic location
Location of the building
Surroundings and topography
Ground reflection

Practical functions

Escape routes
Maintenance, replacement of glass panels and cleaning

Screening requirements

View
Business requirements
Energy and heat
Dazzling, reflections and contrast

Overall solution

External solar protection is a part of a complete solar protection solution. The choice of glass and internal solar protection are important components for a good overall solution.

Descriptive text
Sapa Solar Shading

System

SFB 4550, Sapa Solar Shading

Material

Aluminium profiles, alloy SS-EN AW-6063 according to SS-EN 755-2

Louvre type

Bow, Wing, Box, 190 mm or 300 mm wide

Installation method/fixing type

Vertical screen
Horizontal screen
Self-bearing
Secondary structure

Louvre installation angle

(always relative to the bearing profile)

0°, 15°, 30° or 45°

Distance between louvers

c/c dimension in mm, span in mm

Surface finish – anodising

Nature AA20 according to ISO 7599
Hx 10 champagne AA20 according to ISO 7599
Hx 20 light amber AA20 according to ISO 7599
Hx 30 amber AA20 according to ISO 7599
Hx 40 dark amber AA20 according to ISO 7599
Hx 50 black AA20 according to ISO 7599

Surface finish – powder coating

Polyester powder coating, approx. 60 my
Pre-treatment according to Sapa Building System standard
Colour according to RAL or NCS-S

Sweden*Headquarter*

Sapa Building System AB
S-574 81 Vetlanda
Tel. +46 (0)383 94200
Fax +46 (0)383 761980
www.sapabuildingsystem.se

Denmark

Sapa Profiler A/S
Sapa Building System
8500 Grenaa
Tel. +45 86 32 61 00
Fax +45 86 32 66 63
www.sapabuildingsystem.dk

United Kingdom

Sapa Building System AB
Chester CH4 8BU
Tel. +44 (0)1244 681 350
Fax +44 (0)1244 681 220
www.742060.com

Norway

Sapa Profiler AS
Sapa Building System
2001 Lillestrøm
Tel. +47 63 89 21 00
Fax +47 63 89 21 20
www.sapabuildingsystem.no

Finland

Sapa Profiilit Oy
Sapa Building System
02630 Espoo
Puh. +358 (0)9-8678 280
Faksi. +358 (0)9-8678 2820
www.sapabuildingsystem.fi

Lithuania

UAB Sapa Profiliai
Sapa Building System
LT-08318 Vilnius
Telefonas +370-5 210 25 87
Faksas +370-5 210 25 89
www.sapabuildingsystem.lt

*Headquarter***Sapa Building System AB**

574 81 Vetlanda Tel. 0383-942 00 Fax 0383-76 19 80

E-mail: system.se@sapagroup.com Internet: www.sapabuildingsystem.se

sapa: