

## Railing System Engineering Checklist

Along with this railing packet you will need to provide the following when submitting for a building permit:

- 1.) Engineering for the deck or balcony and drawings that will support the railing system.
- 2.) Post Layout Plan
- 3.) Deck Connection Details (Suggested details included. If you are not using our suggested connection details, please be prepared to provide information on how you will be connecting the railing to the deck or balcony. Please note that you may need to hire an engineer.)

*Please mark the correct railing system for your project.*

**36" Railing System**  
**42" High Railing System**

Which Top Rail are you using on this project?

- Top Rail 100
- Top Rail 375
- Top Rail 200
- Top Rail 999

What infill have you chosen for your project?

- Glass
- Picket
- Cable

How are you connecting the Post to the deck or balcony?

- Top/Surface Mount  
(base plate)
- Fascia Mount  
(side mount)

**Sapa Profiles, Inc.**

**Fabricated Components**

Address: 7320 NE 55th Avenue, Portland, OR 97218 USA

Telephone: 503-802-3467 Toll Free: 800-547-0790 Fax: 503-802-3484

Email: [sapa-inc-rail@sapagroup.com](mailto:sapa-inc-rail@sapagroup.com) Website: [www.sapagroup.com/us/profiles/railings](http://www.sapagroup.com/us/profiles/railings)



Consulting Engineers

75th 97<sup>th</sup> Avenue  
Portland, OR 97216-2427  
(503) 256-3852  
FAX (503) 252-7806

[www.talbotassociates.com](http://www.talbotassociates.com)

November 29, 2007  
TAI File 3016401.0001

Sapa Profiles, Inc.  
7320 N.E. 55th Ave.  
Portland, OR 97218

Attn: Alyssa Stibolt, Fabricated Components

Re: Analysis of Residential Guardrail System

Dear Ms. Stibolt:

Talbot Associates, Inc. (TAI) is pleased to submit this report which summarizes the results of the analysis of Sapa's Residential Guardrail System.

Michael Hagerty, senior engineer for TAI, served as the Primary engineer for analyzing the Residential Guardrail system. Gerald P. Marx, P.E., of TAI was the Technical Reviewing engineer for the analysis.

Previous reports for the Residential Guardrail System prepared by us include one for Sapa dated December 10, 2004 as well as one for the Alumarail division of Anodizing, Inc. dated August 29, 1997.

### CONCLUSIONS

1. The analysis demonstrates that the Sapa Profiles Residential guardrail system meets the requirements of the 2006 International Building Code and 2006 International Residential Code for systems used in one- and two-family dwellings as defined in those codes.
2. The analysis utilizes allowable stress design (working stress design). With few exceptions, the one-third stress increase permitted by Section 1607.7.1.3 of the IBC was not utilized. The analysis provides a suitably conservative demonstration that the residential guardrail system meets the applicable code requirements.
3. Some methods for attaching the railing system to decks or balconies are shown on pages 19 - 22 of the calculations. Because of the great variability of designs and building materials used in residences, other means of attachment of the railing system to

Sapa Profiles, Inc.  
November 29, 2007

Page 2 of 3

the deck or balcony as well as the design of the deck or balcony structural framing supporting the guardrail system and the structural elements for the building containing the deck or balcony are not part of this analysis.

### PRODUCT DESCRIPTION

The Sapa Residential Railing System consists of extruded 6005-T5 aluminum alloy framing members (posts and rails) with aluminum balustrades (for which Sapa uses the term "pickets") or glass balustrade panels or stainless steel cables. (Balustrade material is designated "infill" in the industry.) Aluminum members are connected together with cadmium-coated Torx Drive flat head steel screws and coated with a pigmented enamel finish for durability and aesthetics.

The railing systems are typically sold for use as exterior residential guardrails on balconies, decks, porches, stairs and similar installations where railings are required or desired.

These systems are designed to be partially field-fabricated using stock components. The frames are designed to attach the systems to structures composed of wood and other components. The screw and lag connectors used to connect to the supporting structures should be either hot dipped galvanized steel or stainless steel.

The top railing for these systems is offered in rounded cross-sectional configurations (Series 100 and 999) or flat configurations (Series 375 and 200). Railing sections are fabricated for 5 foot spacing for glass infill systems between vertical posts or 6 foot spacing for other infill. These sections are attached to a short railing block which in turn is attached to the vertical posts. The posts are attached to mounting brackets which are attached to the deck or balcony framing.

### STANDARDS

Sapa products are marketed in the western United States. Therefore, it was determined that standard used for analysis should be the minimum loads specified in the 2006 International Building Code (IBC) and the 2006 International Residential Code (IRC), which are the basis for state building codes in the Western United States.

Guardrails and handrails are required by both codes where safety from falling is involved in the design and construction of buildings. A subset of the load provisions of the IBC are incorporated into the IRC, which is widely used by state building code organizations as the minimum standard for construction of one- and two-family dwellings as well as townhouses.

It was determined that the loading provisions of Table R301.5 of the IRC applied to the Sapa residential railing systems. A copy of the table is attached. Railing Systems are required to withstand a specified loading of 200 pounds applied in any direction to the top rail of guardrails. This load is not required to be concurrent with any other loads.

The terminology of the IBC "be designed to resist" was interpreted to mean that the railing system being analyzed would resist the forces applied without any material yielding (breaking or permanent bending). Because railing system members are not considered to be structural components of a building, the material deflection limit requirements do not apply; however, it is obvious that a railing system must resist minimum loads without plastic deformation which would compromise safety. As a result, the analysis utilizes allowable stress design (working stress design). With few exceptions, the one-third stress increase permitted by Section 1607.7.1.3 of the IBC was not utilized. The analysis provides a suitably conservative demonstration that the residential guardrail system meets the applicable code requirements.

ANALYSIS RESULTS

The analysis is elaborated as follows:

- Calculations.....Pages 1 - 24
- Section Properties.....Pages S1 - S25
- Code References.....Pages R1 - R2

We are pleased to submit this report. Please call us if questions arise.

Respectfully submitted,

TALBOTT ASSOCIATES, INC.



Expires 6-30-2009  
Michael R. Hagerty, P.E.  
Primary Engineer



Expires 12-31-2008  
Gerald P. Marx, P.E.  
Reviewing Engineer

# sapa:

## SERIES 100 PROFILES

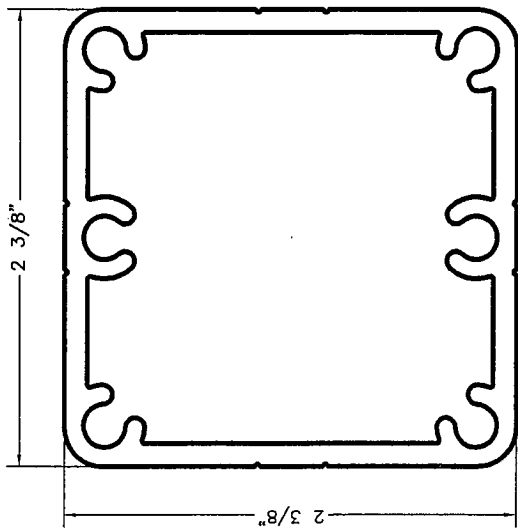

LIGHT COMMERCIAL POST  
FOR 42" HIGH RAILING

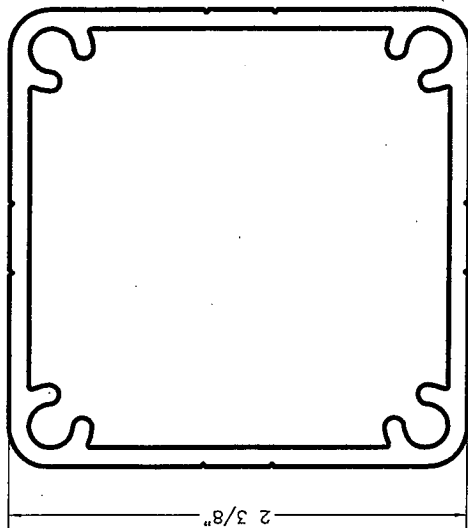

RESIDENTIAL POST  
FOR 36" HIGH RAILING

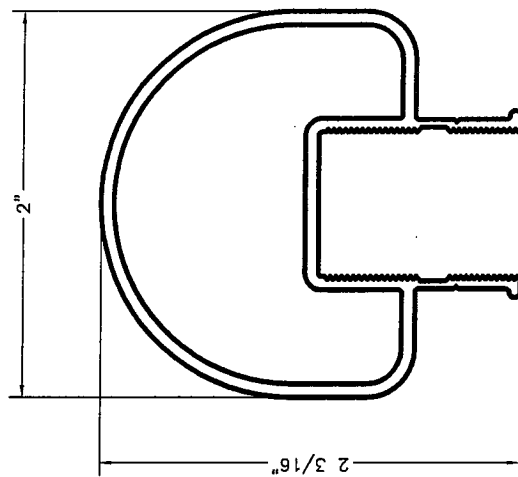

SERIES 100 TOP RAIL

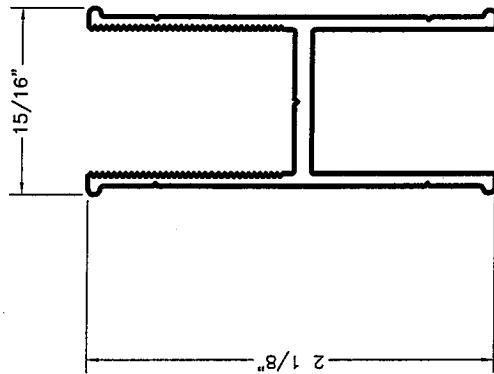

SERIES 100 BOTTOM RAIL

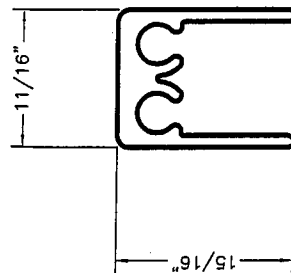
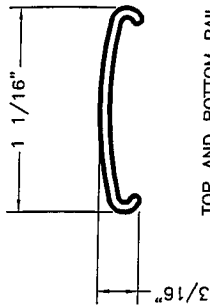
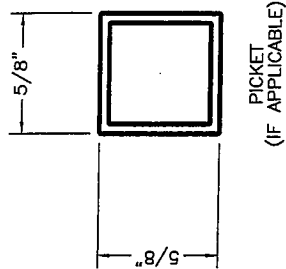

# sapa:

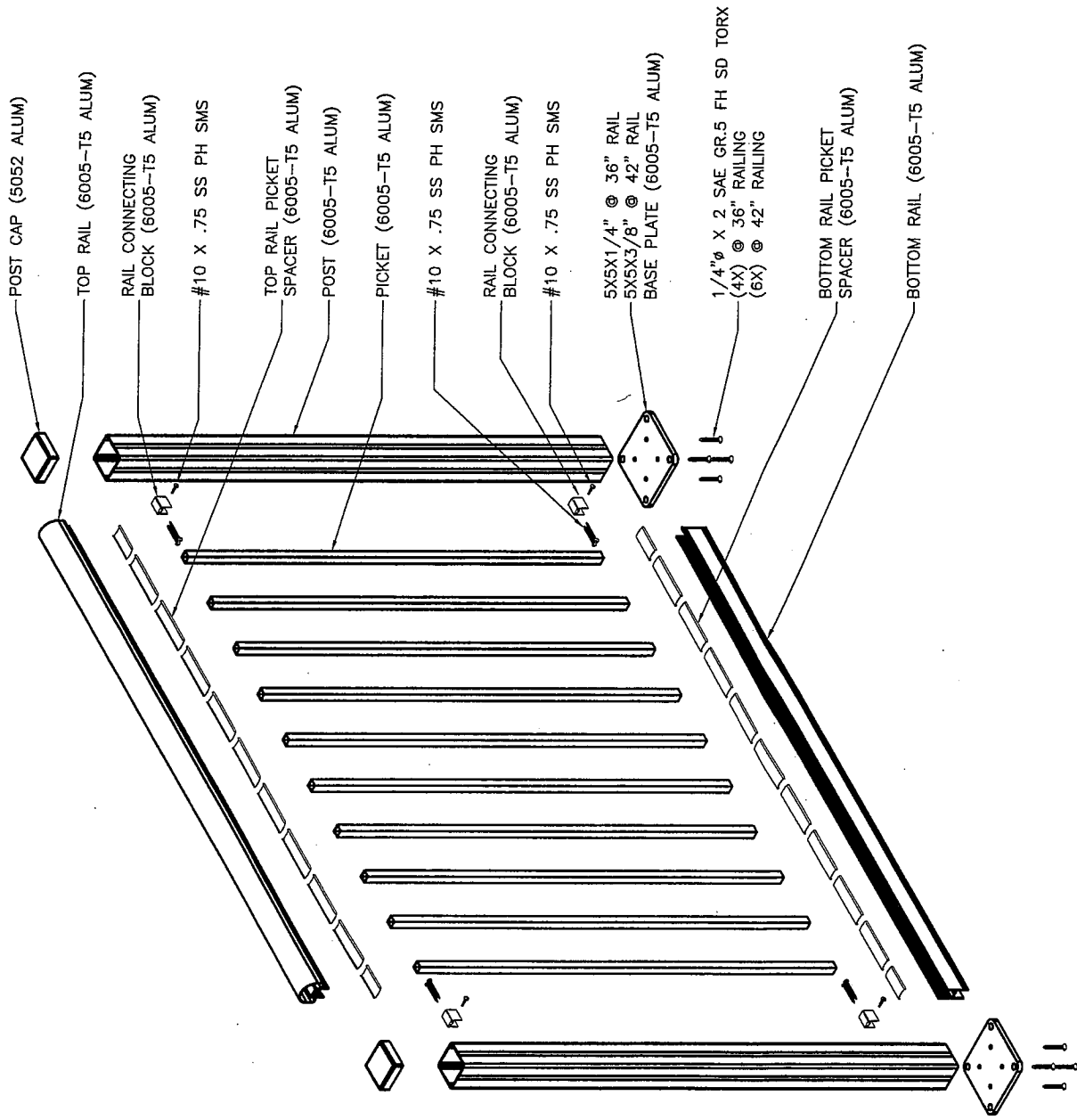

## SERIES 100 PICKET RAILING

**sapa:**

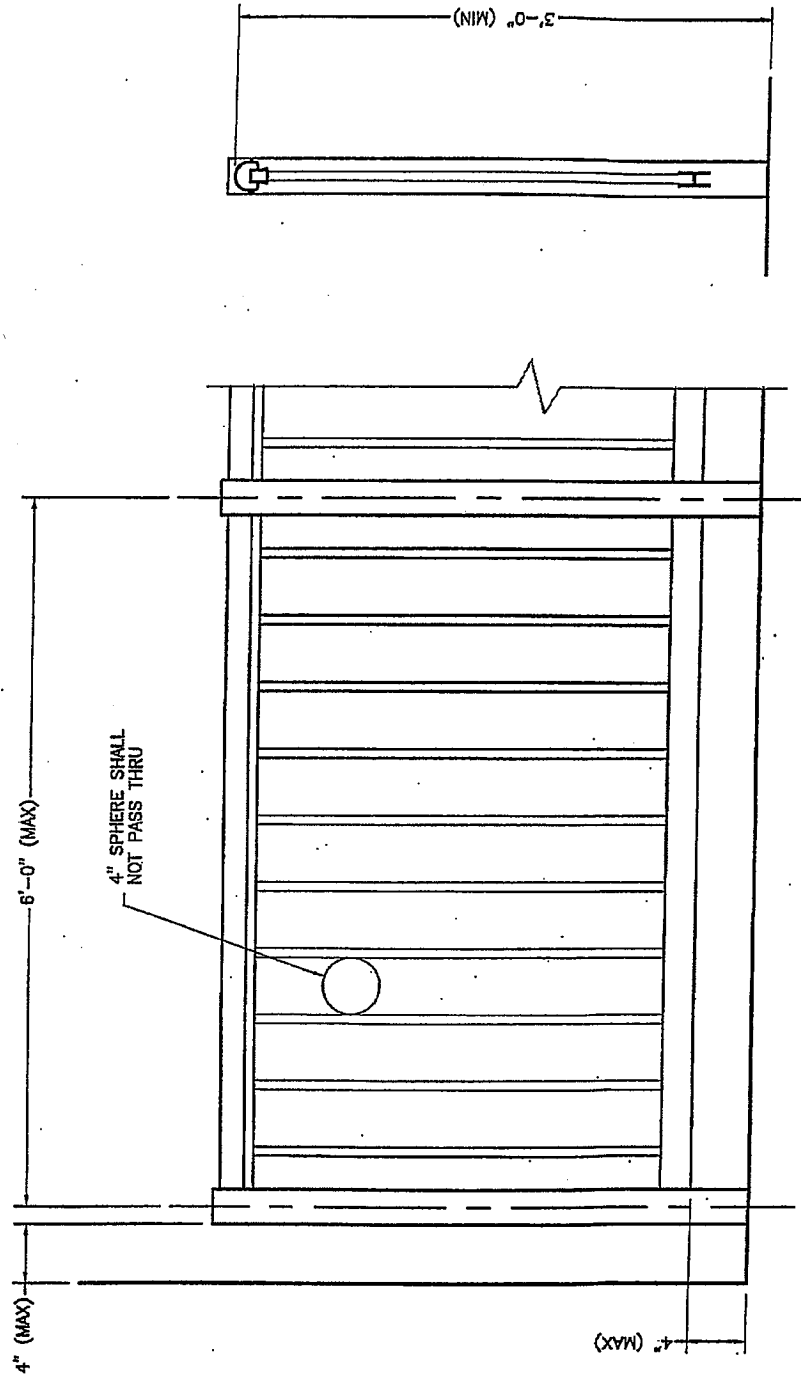

SERIES 100 PICKET RAILING

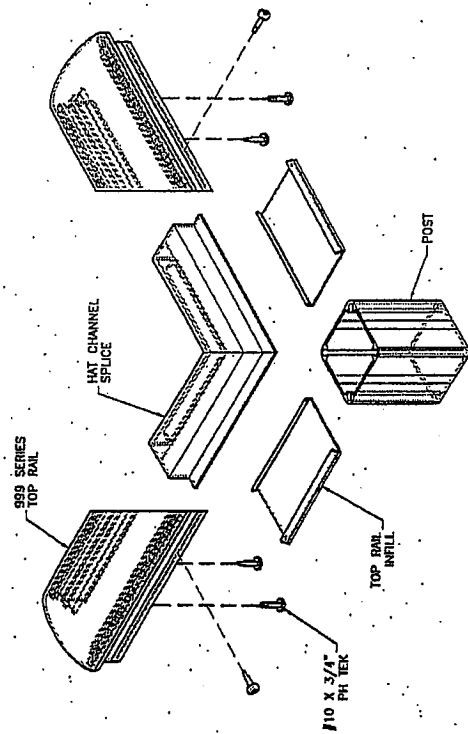

○ TYPICAL TOP RAIL CORNER CONNECTION 3"-1"-0

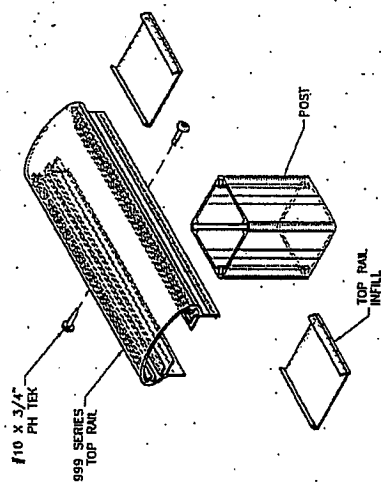

○ TYPICAL TOP RAIL CONNECTION 3"-1"-0

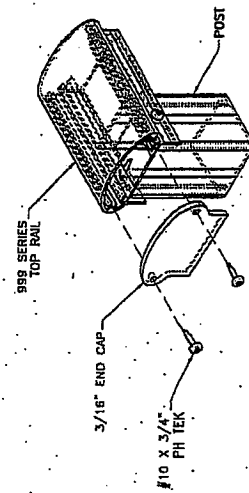

○ END CAP DETAIL 3"-1"-0

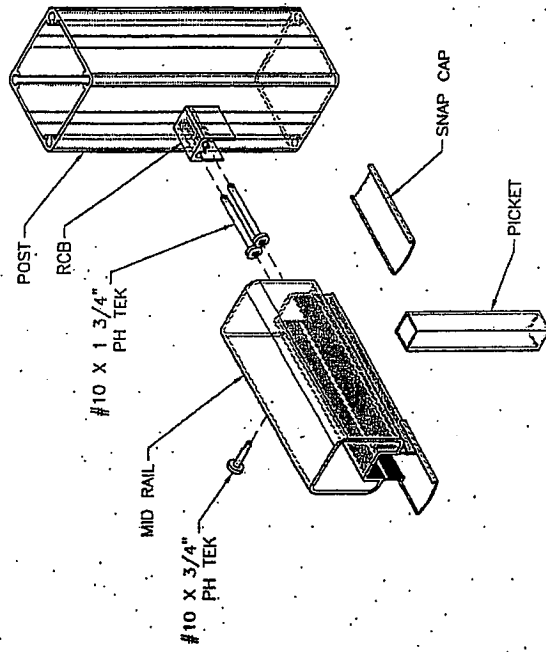

TYPICAL MID RAIL CONNECTION DETAIL  
3"=1'-0"

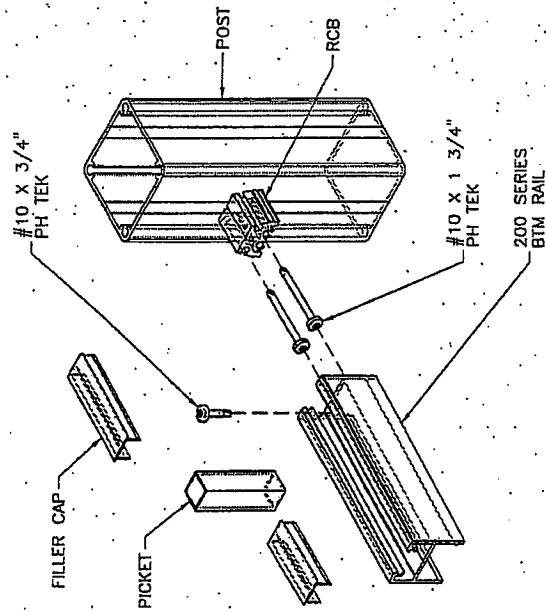

TYPICAL BOTTOM RAIL CONNECTION DETAIL  
3"=1'-0"

# sapa:

## TOP MOUNT RAIL PARALLEL JOISTS

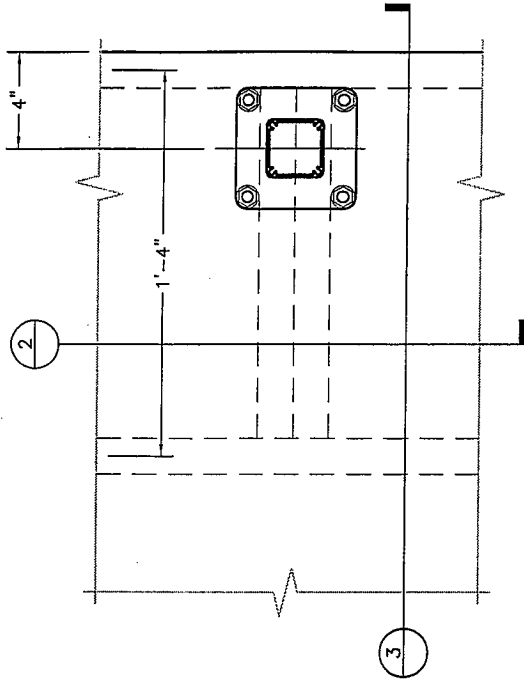

1 PLAN VIEW  
1 1/2"=1'-0"

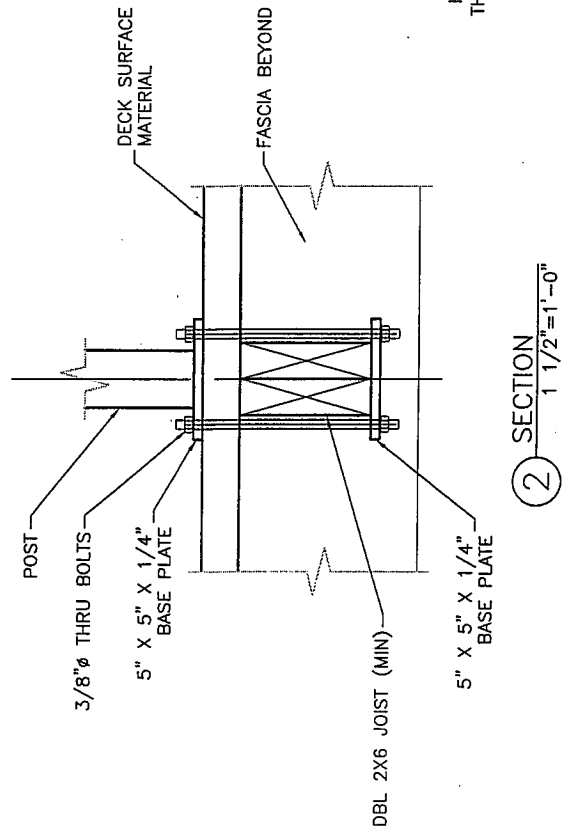

2 SECTION  
1 1/2"=1'-0"

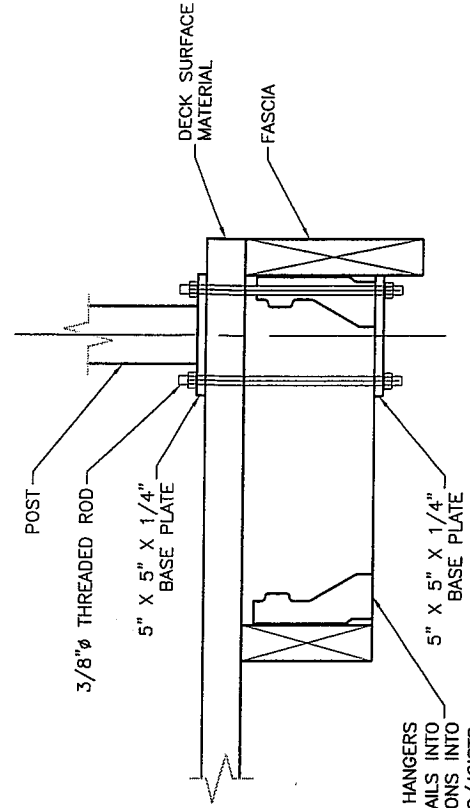

SIMPSON LUS26--2 HANGERS  
W/ 10d X 1 1/2" NAILS INTO  
HEADERS AND 10d COMMONS INTO  
THE DOUBLE 2X6 BLOCKING/JOISTS.

3 SECTION  
1 1/2"=1'-0"

# sapa:

## TOP MOUNT RAIL PERPENDICULAR JOISTS

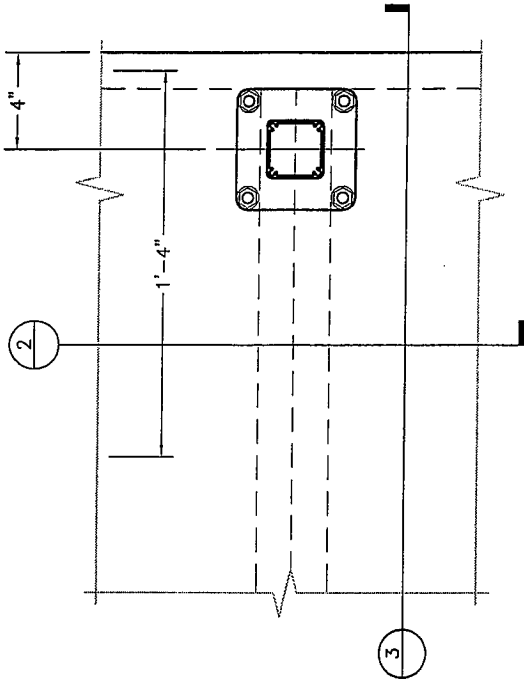

1 PLAN VIEW  
1 1/2"=1'-0"

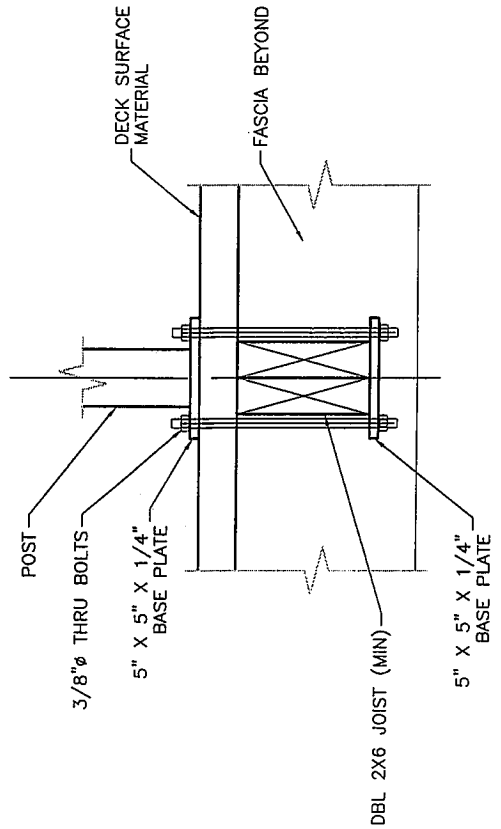

2 SECTION  
1 1/2"=1'-0"

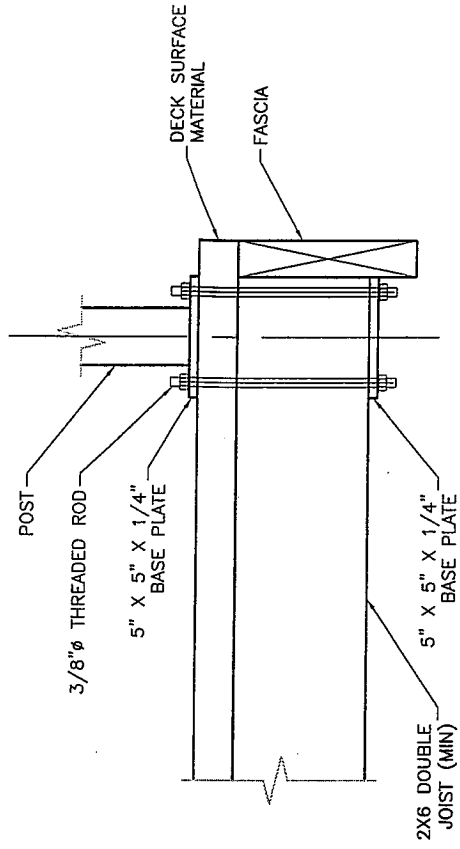

3 SECTION  
1 1/2"=1'-0"

# sapa:

## FACE MOUNT RAIL PARALLEL JOISTS

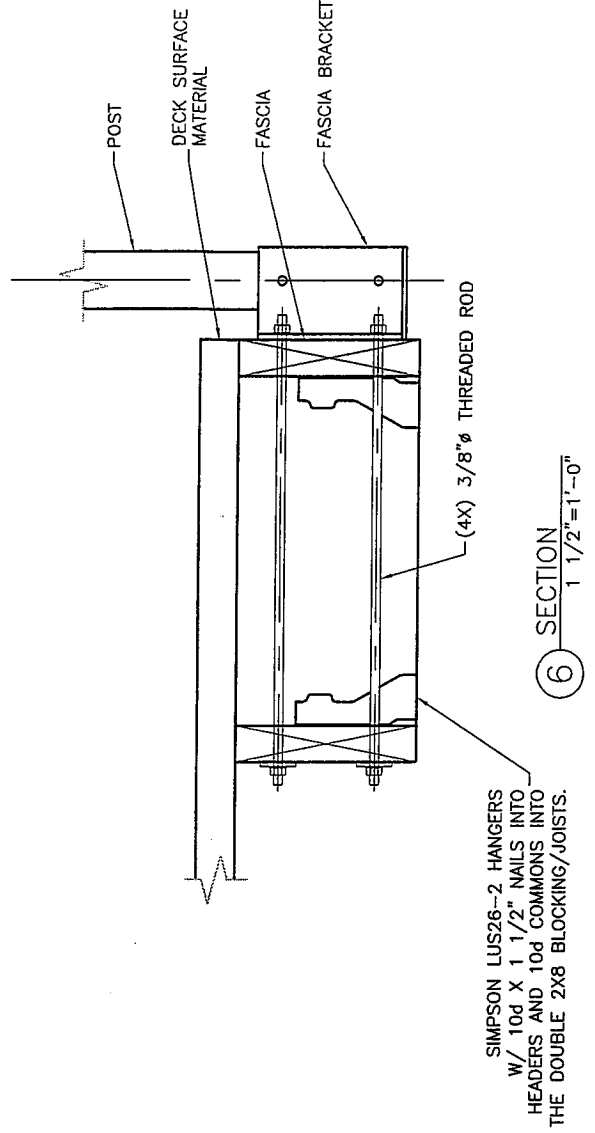
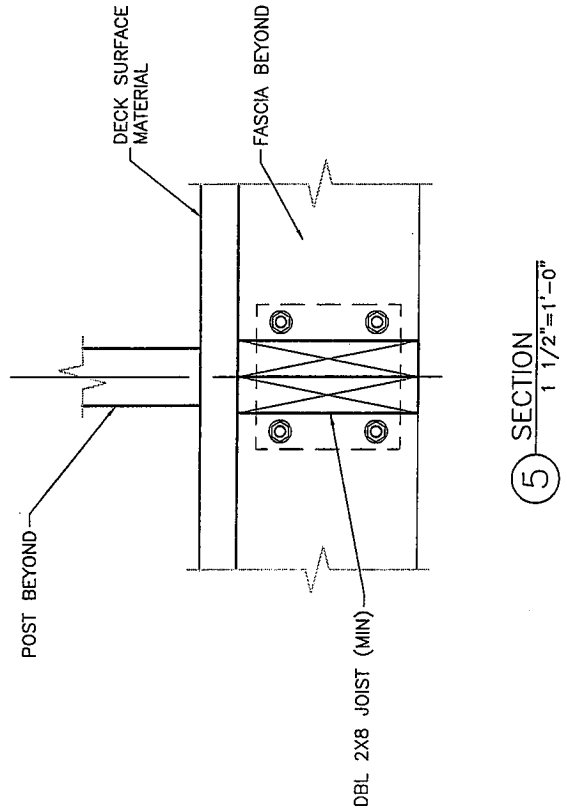
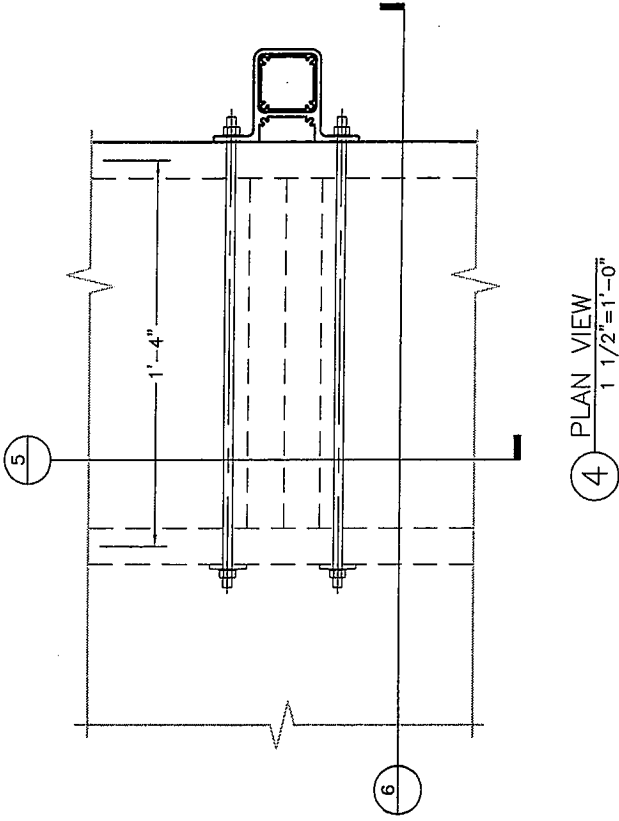

SIMPSON LUS26-2 HANGERS  
W/ 10d X 1 1/2" NAILS INTO  
HEADERS AND 10d COMMONS INTO  
THE DOUBLE 2X8 BLOCKING/JOISTS.

# sapa.

## FACE MOUNT RAIL PERPENDICULAR JOISTS

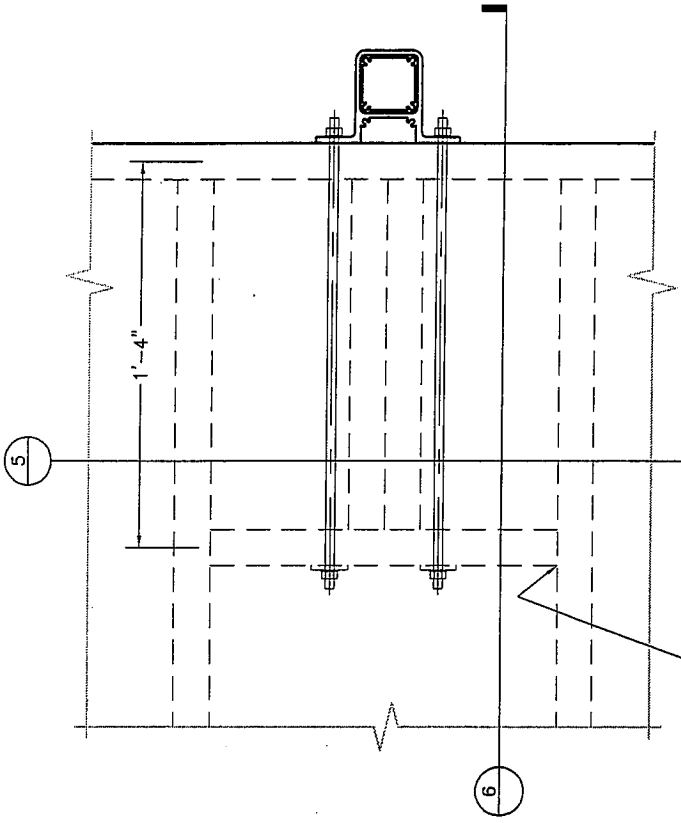

SIMPSON LUS26-2 HANGERS EA. END  
W/ 10d X 1 1/2" NAILS INTO  
BLOCKING AND 10d COMMONS  
INTO THE 2X8 BLOCKING.

4 PLAN VIEW  
1 1/2"=1'-0"

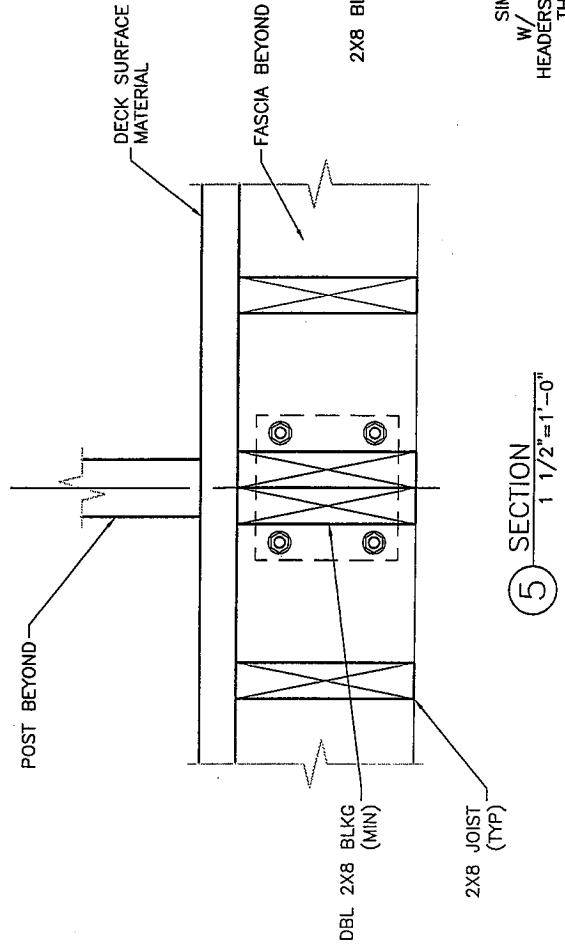

5 SECTION  
1 1/2"=1'-0"

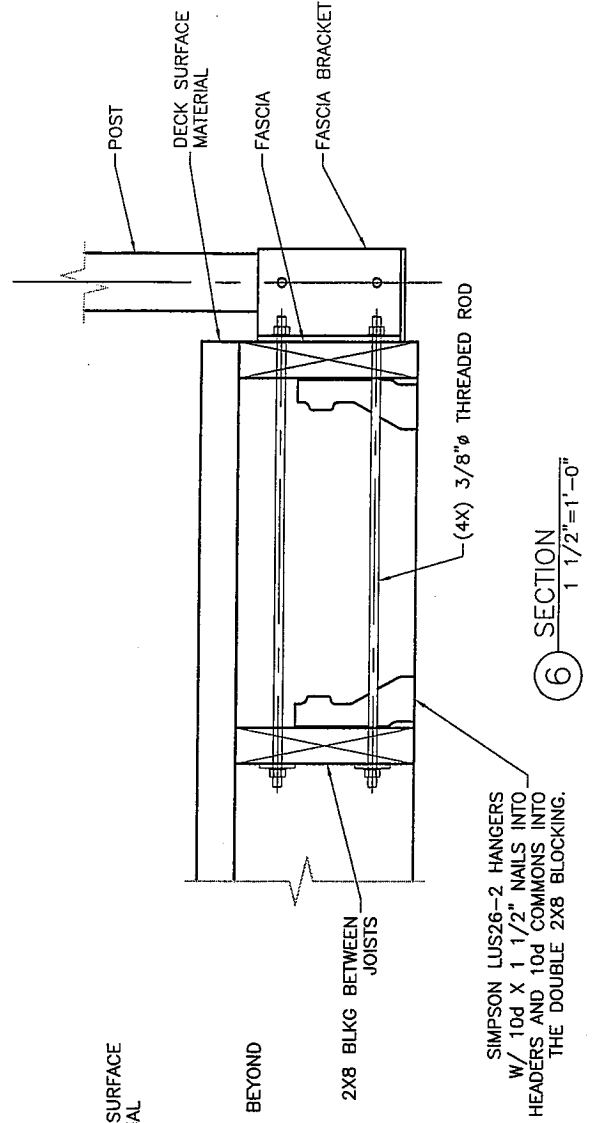

6 SECTION  
1 1/2"=1'-0"